

ENERGY SEAT®





DESIGNATION

sports and auditorium facilities

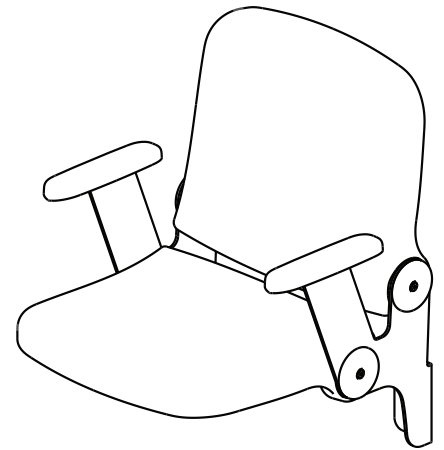
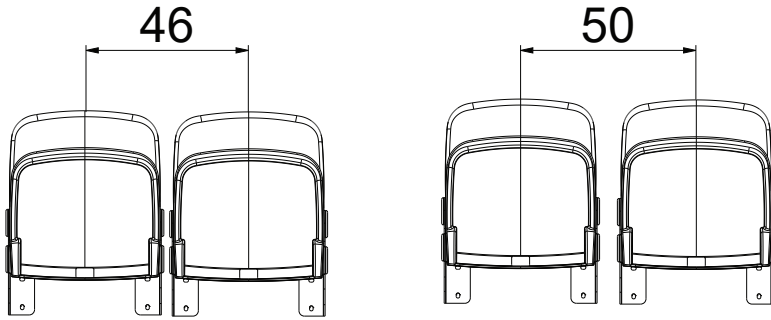

The ENERGY SEAT® automatically folding seat is designed in accordance with the EN13200-4 standard. Its excellent ergonomics result from a design that aims to ensure high comfort while maintaining very good strength parameters. The individual selection of the fastening system means that it can be used in every sports infrastructure project.

The design of the ENERGY SEAT® allows for it to be attached directly to the stand surface individually, or in sets on an aluminium or steel support structure. The unique design of the ENERGY SEAT® hinges ensures that it can be adapted to any type of stadium stands or retractable seating in sports halls. Elements increasing the comfort of use, including armrests and a version upholstered with high-quality materials, allow for the application of the ENERGY SEAT® in business and VIP areas.

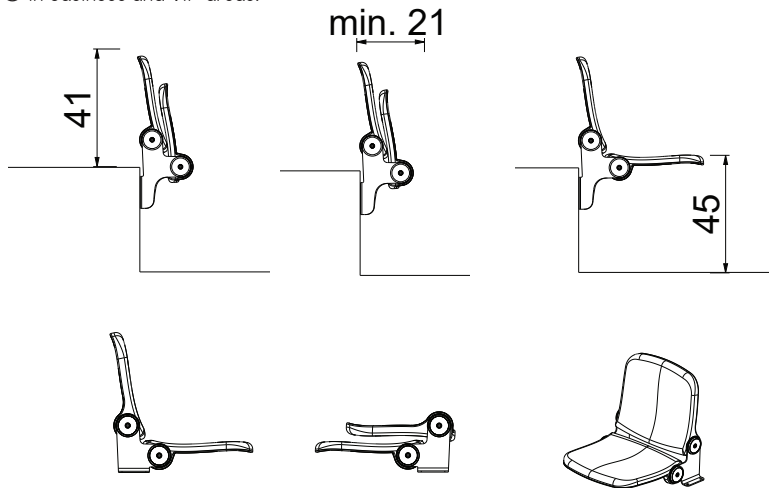
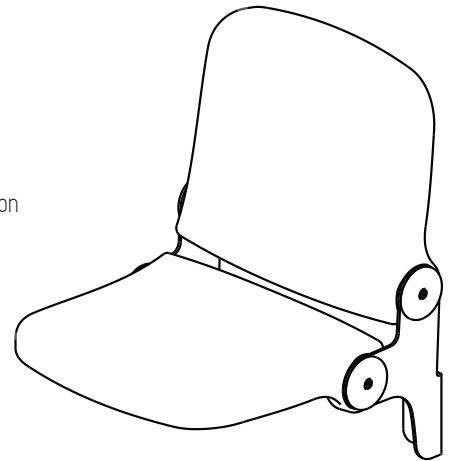

ENERGY SEAT® with folding backrest

A specially prepared method of mounting the seats to the ground for sliding tribunes.

COLOR

The presented colors are visualizations, the colors in reality may differ slightly in shade from those shown below:

